

**EV**

Electrical Vehicle  
Lamination Presses

225 Metric Tons - 410 Metric Tons



---

## Product Overview

Designed specifically for the demands of the electrical vehicle (EV) market, the Minster Electrical Vehicle Lamination press achieves superior part quality, longer tool life and increased operational efficiency.



- 1** Ultra low deflection die space — both bed and slide reinforced for **longer tool life**.
- 2** Hydrostatic/hydrodynamic slide guiding for excellent accuracies to **accommodate the tighter punch-to-die clearances**. Providing superior resistance to off-center loading.



**3** Extremely wide bed to accommodate longer dies of the EV market. Superior deflection characteristics allows for **flexibility** to also run narrower right to left dies.

**4** Industry leading push/pull feed solution can feed material as thin as .20 mm. Also featuring most advanced diagnostics and die control system including servo stack rotation.

**5** Stiffer uprights and stronger crown to minimize deflections and **improve part integrity**.

**6** State-of-the-art Fieldhawk (I4.0) monitoring system — **real time feedback** from gib pressures and vibration levels.

## Standard Features

### Massive Frame Construction

Four-piece, pre-loaded frame utilizing high tensile cast iron in critical areas for the ultimate in vibration and noise dampening. The ultra-low deflection cast bed includes two double walls which reduce front-to-back deflections.

Iron has 2.5 to 4.5 times the dampening capability of steel. Therefore, the EV utilizes castings in all of its beds, slides and uprights to dampen vibration and noise created in high vibration and snap-thru applications.

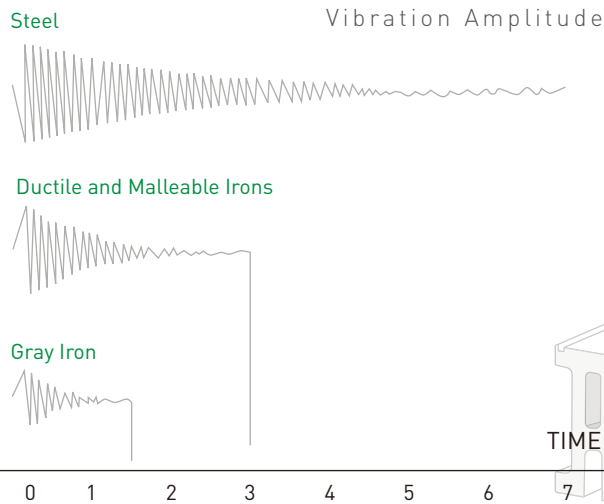

### Lower Deflection & Longer Bed

Nidec Minster's EV has been designed with extremely low deflection providing the ability to run tighter punch-to-die clearance and thin materials while maintaining part quality and achieving a longer die life.

#### Bed Deflection Evolution

PRESS MODEL	BED DEFLECTION
PM3-300-2135	0.080 mm/m
PM4-350-3050	0.067 mm/m
EV-350-3700	0.050 mm/m



## Hydraulic Clutch and Brake Unit

Minster's combination hydraulic clutch and brake produces the maximum torque possible, providing for faster starting and stopping. A patented segmented drive disc design provides safe and reliable operation, variable clutch torque and easy maintenance.

Segmented friction material allows for easy replacement without removal of the clutch and brake discs. In addition, Minster's clutch and brake unit requires no adjustment, resulting in less downtime and higher production rates.

Stopping Angle vs SPM ~ EV-350 with 1.18" (30 mm) Stroke

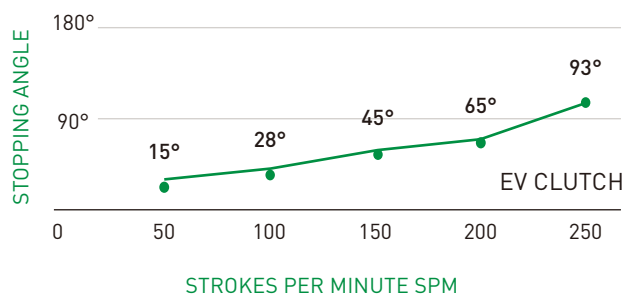

The Minster combination hydraulic clutch and brake provides the ability to single stroke at high rates while simultaneously providing unparalleled stopping time ability that is critical for high speed and in-die sensing applications.

## Large Tie Rods

All EV presses have large tie rod nuts with rolled threads. Rolled threads are capable of handling up to three times the load of standard cut threads. This added capability is essential in the event of an overload situation.

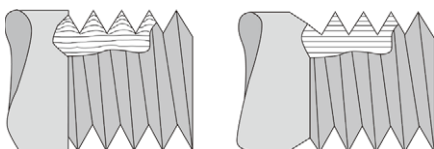

Rolled Threads

Cut Threads

## Eight-Point Hydrostatic/ Hydrodynamic Gibbing For Precision Slide Guiding

The EV slide guiding system incorporates both hydrostatic and hydrodynamic bearing technology. This combination of technologies provides:

- Greater resistance to off-center loading than either standard oil film or roller bearing guided gibs.
- Extreme overload capacity for shock loading.
- Centering of slide in a static condition.

## Hydrodynamic Drive Bearings

### Advantages of Hydrodynamic Bearings:

- Indefinitely long life with full film lubrication.
- High load capacity.
- Load capacity and stiffness increase w/speed.
- Extreme overload capacity for shock load.
- High vibration dampening.
- Replacement involves only limited disassembly.

### Roller Bearing Weaknesses:

- Statistically predictable limited life.
- Shock load capacity no greater than static load capacity.
- Severe overloads produce brinelling.
- Replacement involves extreme disassembly.

## Standard Features

### Hydrostatic Gib Monitoring

This system will top stop the press if the gibs' clearance is closed-in due to a set up problem or other issue. The hydrostatic gib monitoring system is comprised of 12 pressure transducers positioned in the lubrication circuit to sense the gib clearance on both the main and auxiliary gibs.

### Reverse Load Rating

The combination of the EV's hydrodynamic drive bearings, forged eccentric shaft, heavy ductile connections, full wrist pins, and slide adjustment screws with hydraulic locked buttress threads, provide the EV with a reverse load rating 2 to 4 times that of standard presses. This high rating minimizes punch penetration and provides increased capability for blanking and piercing applications.

### Full Wrist Pins

Full wrist pins, supplied with high-pressure oil, provide superior snap-thru ratings with reduced wear and deflection. The high tensile stiffness of this design results in improved bottom-dead-center repeatability along with reduced die punch penetration which are critical during high tensile blanking operations. In a snap-thru condition, a wrist pin is subjected to pure shear forces while the connection is only subjected to simple tension forces. Comparatively, when a ball and socket design is subjected to snap-thru, in addition to the shear and tension forces, the ball bushing and retainer are also subjected to bending moments which create a more severe stress situation.

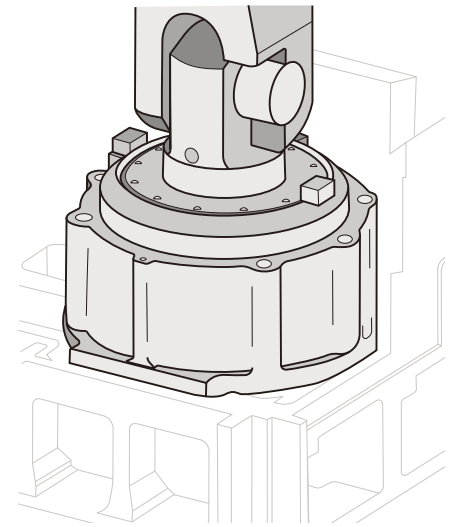

## The Basics of Hydrostatic / Hydrodynamic Technology

Twelve separate hydrostatic pads are machined into the extra-wide gib surfaces of the EV. When an off-center force attempts to tip the slide, the oil pressures at these pads change independently to offset the force and maintain exceptional slide parallelism.

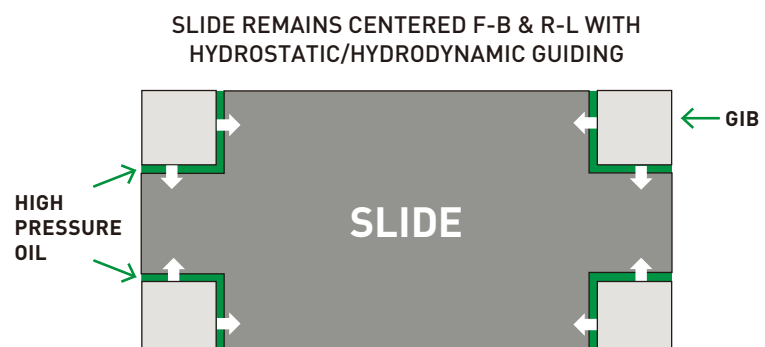

## Eccentric Shaft

Minster's one-piece forged eccentric crankshaft is precision ground, holding high throw-to-throw accuracies that provide superior dynamic parallelism and increased die life in close tolerance dies. Eccentric shafts provide more accuracy and higher rigidity than eccentric gears or crankshafts, and they have approximately 33% more load bearing area and less deflection than a standard crankshaft. This design significantly increases the press's ability to handle snap-thru forces as compared to a crankshaft or eccentric gear design.

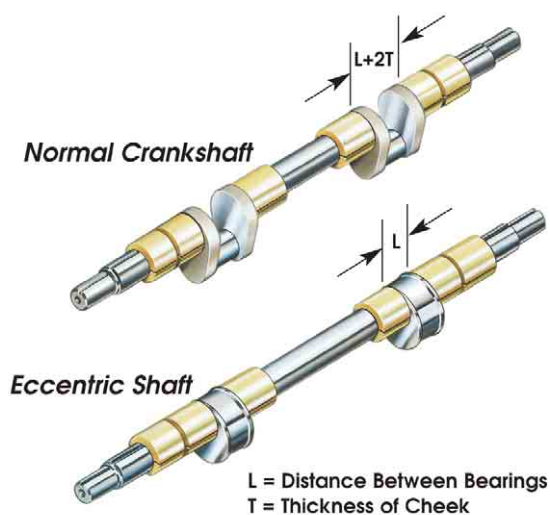

## Flywheel Drive Arrangement For Maximum Efficiency

Minster EV Series presses are flywheel type presses running at higher speeds for punching and blanking operations on ultra thin lamination materials.

The clutch and brake unit is mounted on the eccentric shaft and the flywheel rotates on anti-friction bearings.



## Standard Features

### Quick Access Feature

- Allows user to raise the slide 3" (75mm) providing quick and easy access to thread material, inspect the die or release material.
- Eliminates need for hydraulic tie rod nuts.
- After use, mechanical stops ensure the slide is returned to the exact shutheight position and parallelism that it maintained prior to use. This is not possible with a screw-type mechanism.
- Allows the user to select a press with a minimum stroke length for the application without sacrificing the operator's ability to inspect or change tooling.
- The pressurized quick lift chamber provides a preload exceeding the press tonnage.

### Drive Motor

The EV variable frequency main drive motor is totally enclosed, fan cooled, variable speed and provides proven durability and increased torque response to offer these benefits:

- The latest in press drive technology with Auto-Tune set-up.
- Simplified control unit for easy troubleshooting.
- Interchangeable controller.
- Belt pull will not affect internal motor bearings.

### Monitored Lubrication With Variable Frequency Regulation

All main and connection bearings have full film lubrication with pressurized oil supplied to each bearing from within the crankshaft. This system is designed to stop the press in the event of reduced oil pressure, thereby preventing damage to the machine. A variable speed lube pump motor with pressure transducer feedback maintains constant oil pressure through plant ambient and press temperature variations. The consistent oil film gives the ultimate dynamic bearing stiffness and longevity resulting in better bottom-dead-center repeatability and longer die life.

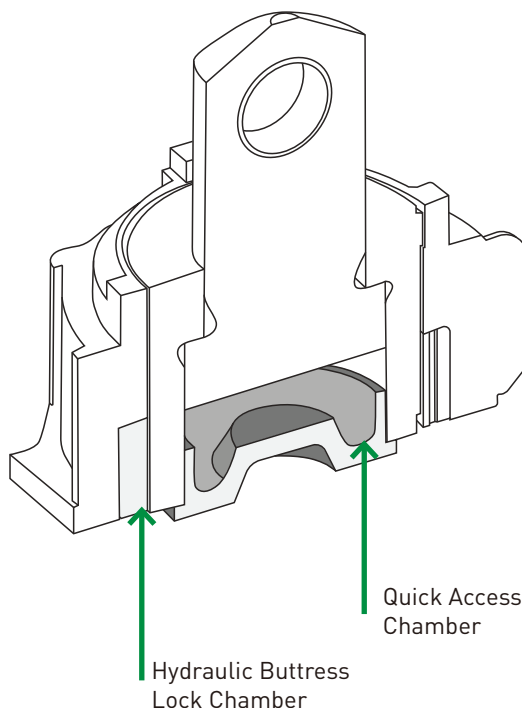

### Hydraulic Locking

Clearance in the slide adjustment screw and nut mechanism are eliminated by compression of the nut diameter with high pressure oil. This reduces vibrations resulting from snap-thru forces during blanking, improves die life, and eliminates the possibility of the slide adjustment "creeping" under load.



---

## Motorized Slide Adjustment

The slide adjustment on the EV is driven by a hydraulic motor connected to hardened worm shafts with zero backlash couplings and is supported on anti-friction bearings. The adjustment mechanism includes a shock mounted electronic encoder to display and adjust shutheight on the press console.

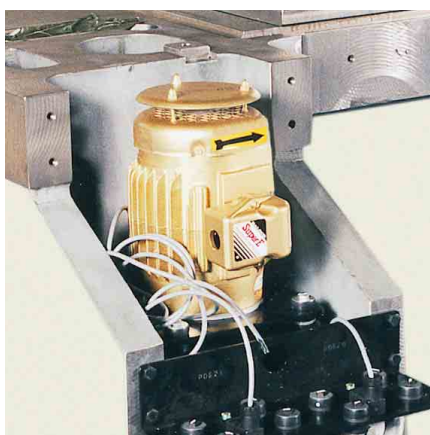

Lube motor pump assembly mounted in right hand rear press bed leg.



Hydraulic motor pump assembly mounted in left hand rear press bed leg.

---

## Electrical Standard Features

- Control Pedestal Located on Feed Side
- Pedestal-Mounted Control Station
- Pedestal-Mounted Run Station
- Press Stop Control Buttons Mounted on Each Upright
- Two Press Top Stop Control Buttons (One each on front and rear)
- 16-Pole Programmable Limit Switch
- Non-Reversing Drive Motor Starter
- Setup Station on Uprights or on Sliding Pendant

---

## Flywheel Brake

The flywheel brake design on the Minster EV gives the operator the ability to quickly slow the flywheel to a pre-set speed. The combination of an increased brake contact area, reduced surface contact pressure, and increased usable lining thickness provides 7 to 10 times the life of a normal brake lining.

---

## Isolation Press Mounts

Isolation press mounts are included and standard on Minster EV presses.



## Standard Features

### Production Management Control (PMC)

Incorporates all press functions including:

- Full machine diagnostics detailing all press and feed line faults.
- Multiple selectable languages.
- Open architecture which allows for greater convenience in planning and maintenance.
- PLC and color touch screen technology; all press and feed line functions can be monitored for efficient diagnosis of production line faults.

Available popular options include: die protection, load monitoring as well as automatic shutheight and counterbalance controls.

*Available in Allen Bradley, Siemens, or Mitsubishi.*

### FieldHawk - i4.0

FieldHawk is a cloud-based mobile application designed to communicate with your Nidec stamping press lines from your iOS or Android mobile devices. Cloud-based, secured communications allows all authorized users to check machinery status from anywhere you can get phone service and/or an internet connection, thus reducing downtime.

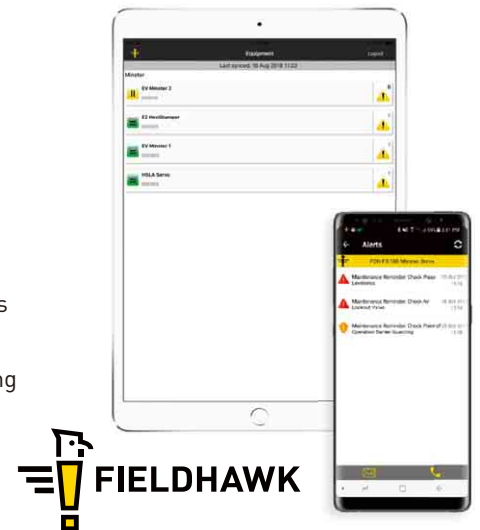

---

## Optional Features

---

### **Dynamic Balancing**

The optional Dynamic Balancing system on the EV press greatly reduces the effect of the slide inertia forces caused by running at high speeds. This reciprocating balancer helps maintain precise slide bottom-dead-center repeatability resulting in less die wear and greater part accuracy. It also allows the press to run at higher speeds and reduces press vibration.

### **Automatic Shutheight Adjustment**

Will automatically set the shutheight to the predetermined tool storage value, reducing setup time. Manual shutheight adjustment can still be achieved via the operator's input on the control.

### **Load Monitoring**

### **Die Protection**

### **Coil Line Interconnects**

### **Additional Part Blow-Off Valve**

### **Die Area Guarding**

---

### **Adjust-In-Motion (AIM)**

- Allows micro-adjustment while running.
- Accurate change feedback.
- Helps maintain bottom-dead-center repeatability.



# Specifications & Dimensions

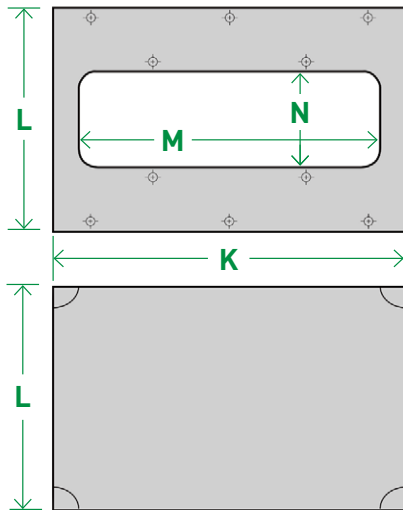
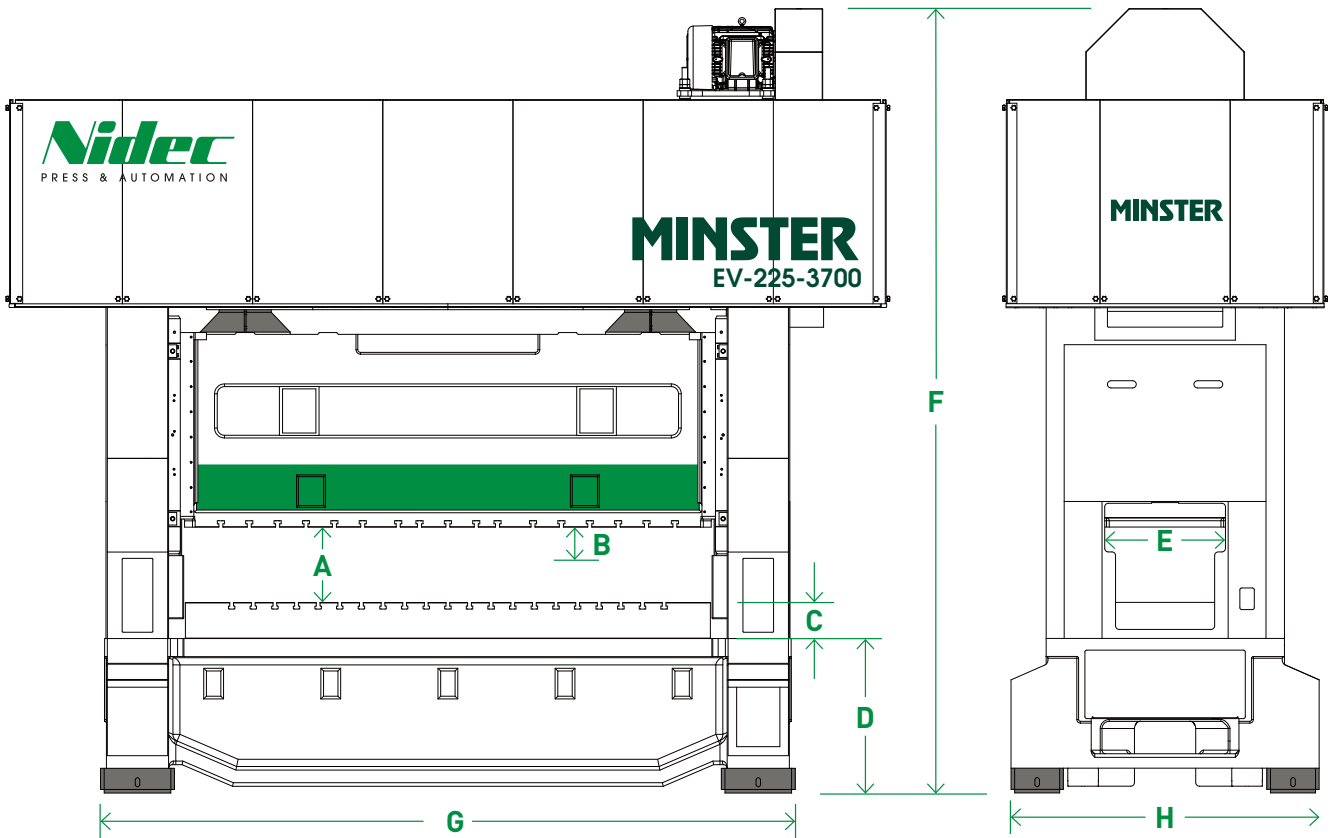

	EV-225 (250)	EV-315 (350)	EV-410 (450)			
Drive Type	Flywheel Drive	Flywheel Drive	Flywheel Drive			
Tons Capacity	250 @ 0.06" off bottom 2225 kN @ 1,6mm	350 @ 0.06" off bottom 3100 kN @ 1,6mm	450 @ 0.06" off bottom 4000 kN @ 1,6mm			
Slide Stroke vs. Speed * Maximum speed applies to balanced configuration. Contact Nidec Minster for speeds of non-balanced design.	Stroke	Maximum Speed*	Stroke	Maximum Speed*	Stroke	Maximum Speed*
	1.18" 30 mm	350 spm	1.18" 30 mm	350 spm	1.18" 30 mm	350 spm
	1.38" 35 mm	350 spm	1.38" 35 mm	350 spm	1.38" 35 mm	325 spm
	1.57" 40 mm	325 spm	1.57" 40 mm	325 spm	1.57" 40 mm	300 spm
Quick Access Slide Travel	2.95" ~ 75 mm	2.95" ~ 75 mm	2.95" ~ 75 mm			
<b>E</b> Upright Opening	27.6" ~ 700 mm	27.6" ~ 700 mm	41.5" ~ 1054 mm			
<b>KxL</b> Area of Bolster and Slide (R-L x F-B)	145.7" x 47.4" 3700 x 1205 mm	145.7" x 47.4" 3700 x 1205 mm	145.7" x 55" 3700 x 1400 mm			
<b>MxN</b> Opening in Bolster (R-L x F-B)	129" x 13.8" 3275 x 350 mm	129" x 18.5" 3275 x 470 mm	130" x 19.7" 3300 x 500 mm			
Opening in Bed (R-L x F-B)	136.5" x 15.0" 3467 x 380 mm	136.5" x 19.0" 3467 x 483 mm	136.5" x 20.5" 3467 x 520 mm			
Flywheel Energy	26.5 In. Tons @ 75 spm	32 In. Tons @ 75 spm	36 In. Tons @ 95 spm			
Max. Upper Die Weight	5400 lbs ~ 2450 kg	7500 lbs ~ 3400 kg	8800 lbs ~ 4000 kg			
Main Bearing Diameter	8.5" ~ 216 mm	8.5" ~ 216 mm	9.5" ~ 241.3 mm			
<b>A</b> Shutheight Range on Bolster (S.D.A.U.)	21.65" ~ 550 mm	23.62" ~ 600 mm	26.57" ~ 675 mm			
<b>B</b> Shutheight Adjustment	3.94" ~ 100 mm	3.94" ~ 100 mm	3.94" ~ 100 mm			
<b>C</b> Bolster Thickness	9.84" - 13.78" 250 - 350 mm	9.84" - 13.78" 250 - 350 mm	9.84" - 13.78" 250 - 350 mm			
<b>D</b> Floor to Top of Bed (with Mounts)	42.9" ~ 1090 mm	51.5" ~ 1308 mm	53.5" ~ 1360 mm			
<b>F</b> Overall Height (with Mounts)	218.5" ~ 5550 mm	230" ~ 5842 mm	249" ~ 6325 mm			
<b>G</b> Floor Space (R-L)	193" ~ 4902 mm	193" ~ 4902 mm	207" ~ 5260 mm			
<b>H</b> Floor Space (F-B)	91.3" ~ 2320 mm	102.6" ~ 2605 mm	141" ~ 3580 mm			
Approximate Weight/Balanced	185,000 lbs/215,000 lbs 83,920 kg/98,000kg	195,000 lbs/220,000 lbs 88,450 kg/100,000kg	330,000 lbs/375,000 lbs 149,700 kg/170,000kg			

---

## EV Full Product Integration

### A total system solution: MINSTER EV Press + VAMCO EV Automation

The world's fastest feeding system for thin laminations. Nidec Press & Automation has taken the power and technology of Minster presses and Vamco automation to offer a total system solution for EV laminations. Nidec branded press line components offer full OEM integration prior to installation, increasing operator ease of use, system integration uptime/value and reduction of required space.

---

Reel

---

Straightener

---

Loop Control

---

Push/Pull Feeds

---

Press

---

Die & Stack Height Control

---

Stack Rotation

---

Scrap Cutter

---







**One Brand: A World of Resources**

Nidec Press & Automation is the full service pressroom provider of choice for businesses in more than 90 countries and on six continents. Comprised of leading press room product brands, we ensure a complete offering of machinery, services and technology to meet your exact needs, enabling you to rely on one source.

Discover the freedom to achieve, to maximize and to drive your operation to exceed your goals. At Nidec Press & Automation, your success is the core of our focus and how we design our solutions to meet the rigid needs of the metal forming industry.

Choosing to work with us means you gain a constant resource with a global footprint, the brightest minds behind our solutions, and backed by regionally based OEM support ready to work as a natural extension of your team.

**Our promise to you is simple:  
We're with you whenever and wherever  
business takes you.**



**MACHINERY**

- Turn Key Systems
- Individual Components
- System/Tech Upgrades
- i4.0 Software Upgrades
- Integrated Controls

**METAL FORMING PRESS APPLICATIONS**

- Mechanical
- Servo
- Transfer
- High-Speed & Electrical
- Electrical Vehicle (EV)
- Lamination
- Container Cupping
- Container End-Conversion
- Container Shell
- Gap/D-Frame

**AUTOMATION**

- Press Tending / Robotics
- Integrated Transfer
- Systems
- High Speed Servo Feeds
- High Speed Gripper
- Feeds
- Heavy-Duty Coil Lines

**GLOBAL SERVICE NETWORK**

- Field Service
- Emergency Response
- Technical Service & Support
- OEM Replacement Parts
- Machine & Component Remanufacturing
- Technical Training





## One Brand: A World of Resources

---

A single source solution that will help you find the efficiencies you want — all from the products, services and technology of Nidec Press & Automation.

[nidecpa.com](http://nidecpa.com)